

PLT

"PLT" SERIES' 350 Ohm NIKEL-PLATED LOAD CELL KITS FOR ASSEMBLING FLOOR SCALES



Ideal for creating platforms with 4 load cells of various sizes and capacities. The kit is made up of 4 350 Ohm IP67 nickel-plated load cells, OIML and NTEP approved, together with adjustable resting feet and an equalisation box.

**The best solution
for advanced industrial
applications**

LOAD CELL TECHNICAL FEATURES

- Minimum load cell verification interval $V_{min} = E_{Max} / 10.000$
- Maximum number of verification intervals $n_{LC} = 3000$
- Combined error 0,017% of Full Scale Output (F.S.)
- Nonlinearity $\pm 0.02\%$ FS
- Hysteresis $\pm 0.02\%$ FS
- Repeatability $\pm 0.01\%$ FS
- Full Scale Output $2mV/V \pm 0.5\%$
- Zero balance $\pm 1\%$ FS
- Compensated Temperature Range $-10^{\circ}C/+50^{\circ}C$.
- Operating Temperature Range $-20^{\circ}C/+60^{\circ}C$.
- Creep error after 30 minutes $<0,02\%$ F.S.
- Maximum tolerated excitation voltage 15 Vdc
- Input Resistance 380 ± 20 Ohm
- Output Resistance 350 ± 5 Ohm
- Insulation Resistance >5000 MOhm
- Safe Overload 150% F.S.
- Ultimate Overload 300% F.S.
- 6-wire shielded cable, 3.5m long, 5 mm diameter

RESTING FEET

- Adjustable in height
- Nikel-plated steel structure
- Anti-slip base
- Ipsanitizable
- Fitted with locking bush

JUNCTION BOX

- Built-in junction and equalisation board
- IP67 protection from dust and water
- 1 PG9 Fairlead and 4 PG7 Fairleads

DIMENSIONS - DECODING STANDARD CABLE

- NOTE: dimensions in mm

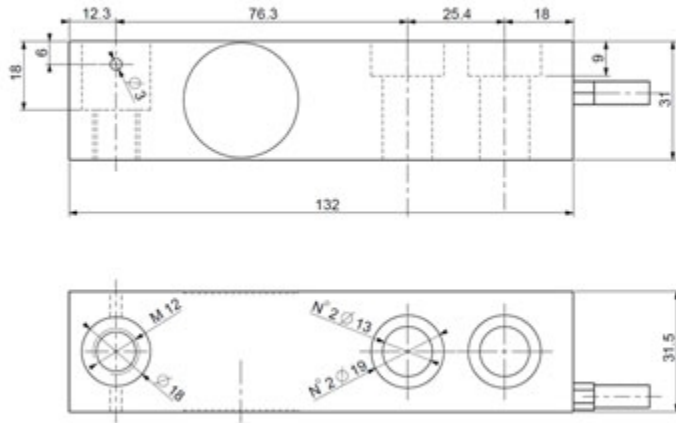

- Decoding of the standard cable colours

Colour	Function
--	SHIELD
YELLOW	OUTPUT +
GREY	SENSE +
BROWN	INPUT +
WHITE	OUTPUT -
GREEN	INPUT -
PINK	SENSE -



www.diniargeo.com



“YOUR WORLDWIDE PARTNER FOR WEIGHING”

DINI ARGEO
FRANCE sarl
Nogent-sur-Marne
info.fr@diniargeo.com

DINI ARGEO
GMBH
Sinsheim - Germany
info.de@diniargeo.com

DINI ARGEO
UK Ltd
Taunton - United Kingdom
info.uk@diniargeo.com

DINI ARGEO WEIGHING
INSTRUMENTS Ltd
Shanghai - China
info.cn@diniargeo.com

DINI ARGEO
WEIGHBRIDGES
Calto (RO) – Italy
info@diniargeo.com



HEAD OFFICE

Via Della Fisica, 20
41042 Spezzano di Fiorano Modena - Italy
Tel. +39.0536 843418 Fax. +39.0536 843521
info@diniargeo.com

SERVICE ASSISTANCE

Via Dell'Elettronica, 15
41042 Spezzano di Fiorano Modena - Italy
Tel. +39.0536 921784 Fax. +39.0536 926654
service@diniargeo.com



SALES AND TECHNICAL ASSISTANCE SERVICE